

“Breadboarding” a Simple FM Transmitter

Assembly Instructions

The New Jersey Antique Radio Club's
Radio Technology Museum
At InfoAge





REV. 0.7.1 – 7 DEC 2016

Your Work Begins Here

- Assemble an FM transmitter prototype
- Observe its operation.

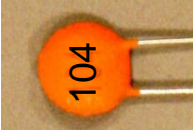
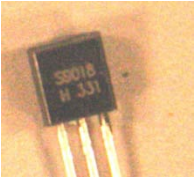
Inventory the Components

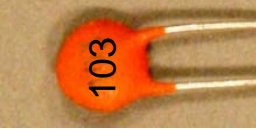
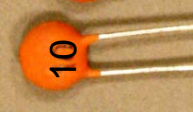
Identify the Components and lay them on this sheet.

RESISTORS	CAPACITORS	MISC.
R2 22K Ohms RED-RED-BLACK-RED-BROWN 	C1, C7 0.1 microfarad "104" 	Q1 Transistor "S9018" 
R3 220 Ohms RED-RED-BLACK-BLACK-BROWN 	C2 0.01 microfarad "103" 	
	C5 10 picofarad "10" 	
	C6 30 picofarad "30" 	

Modern Solder-less Breadboard

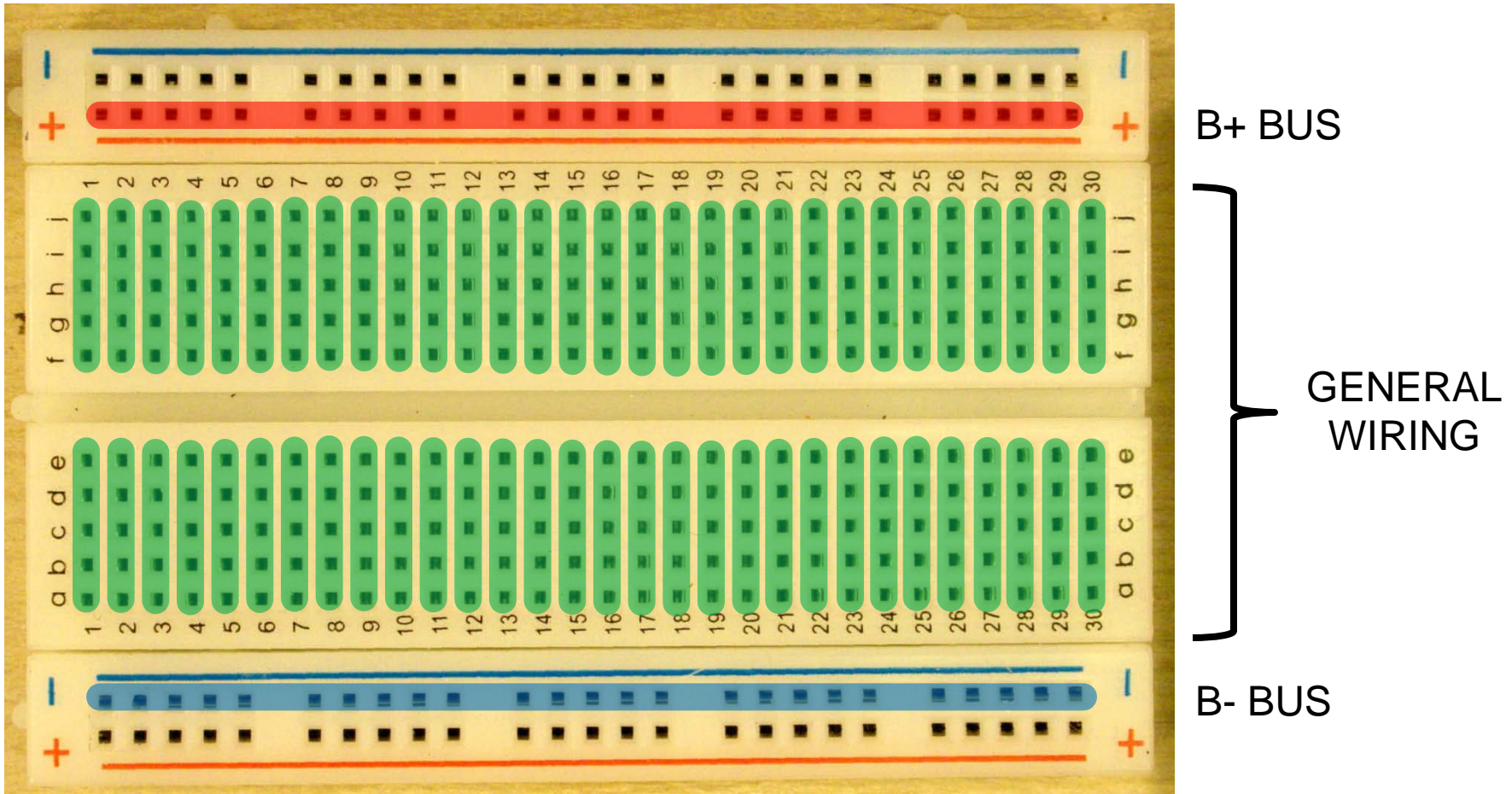

Shaded indicates common connections.

The Schematic Diagram

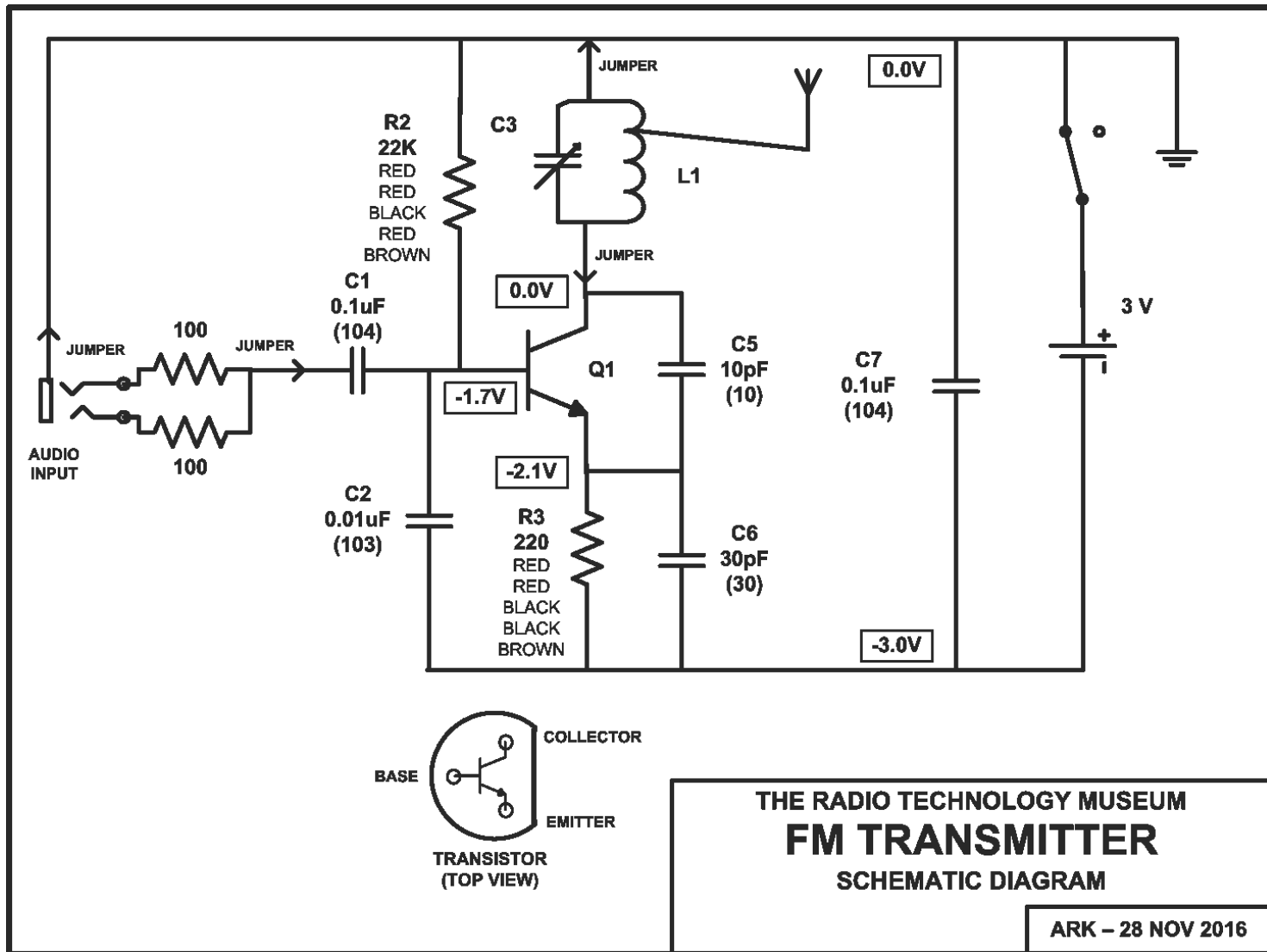

The Setup

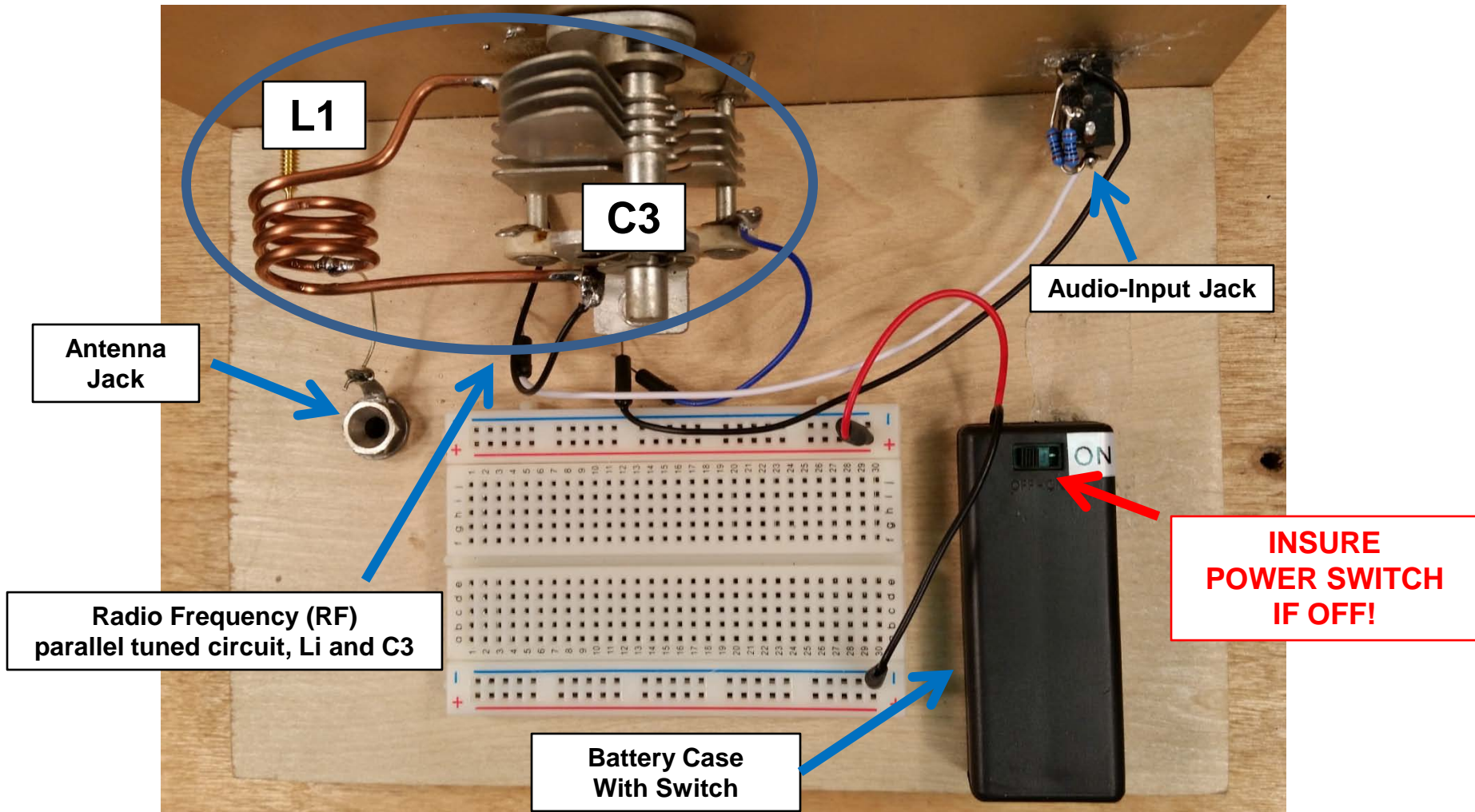

- We've taken care of some mechanical details for you.

Step 1

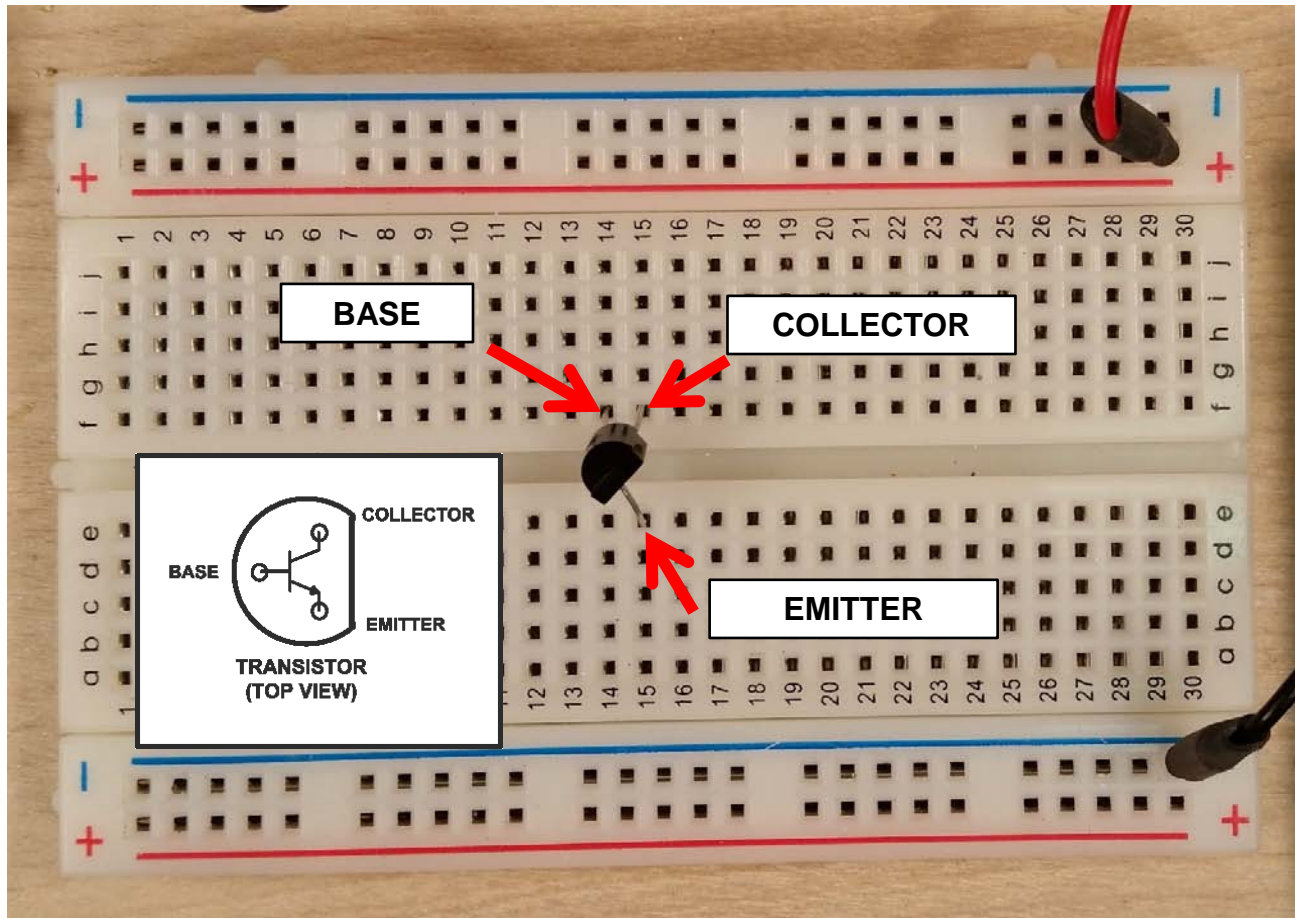

- Install transistor Q1. Observe pin-out diagram.
- (The rest of the circuit will be built around Q1.)

Step 2

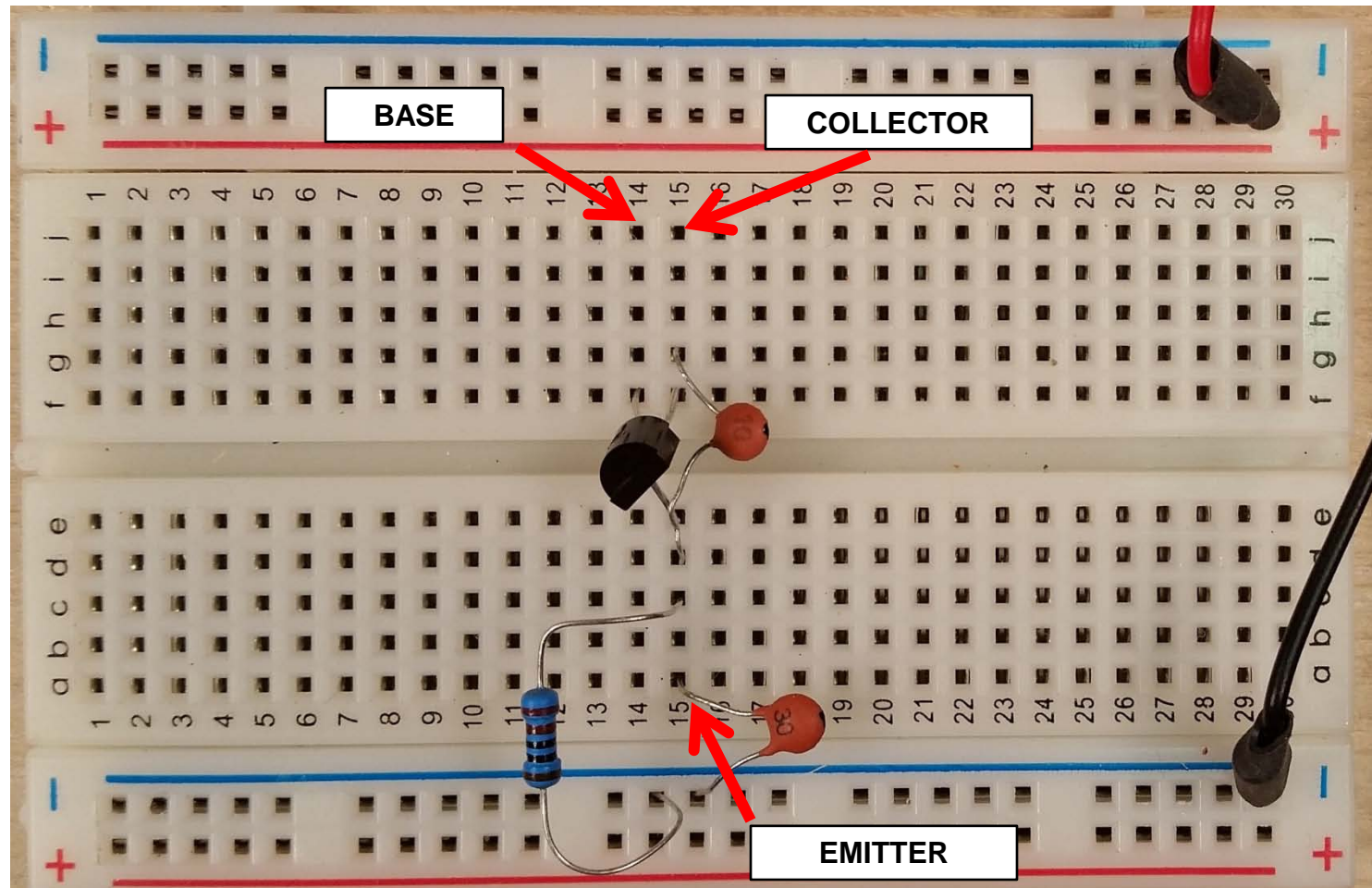

- Install feedback cap, C5 (10pF “10”), between the collector and emitter of Q1
- Install C6 (30 pF “30”) , and R3 (220 Ω - RED RED BLK BRN BRN) in Q1’s emitter circuit..
- NOTE: “p” stands for “pico”, or 1×10^{-9}

Step 3

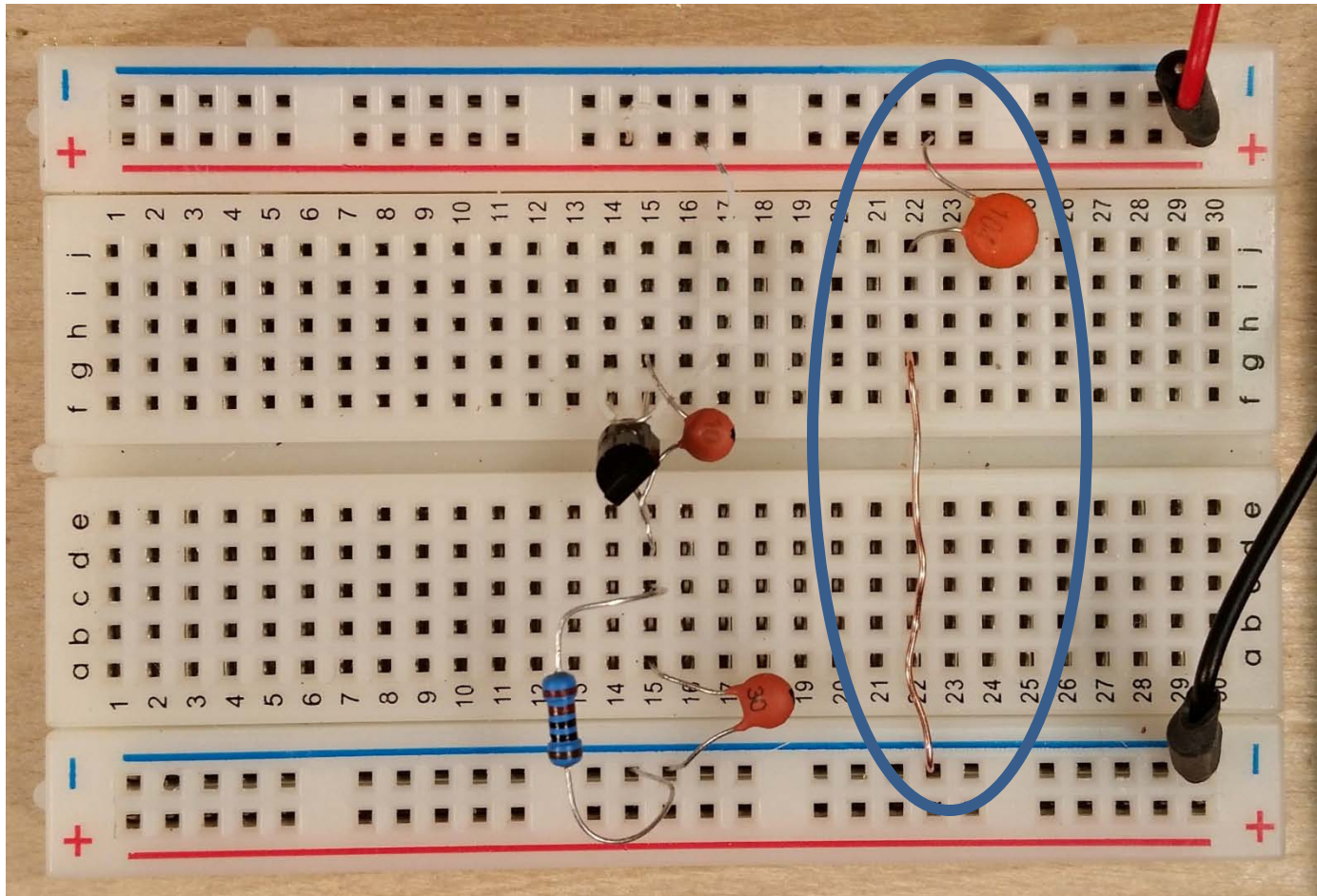

- Install power-bus bypass cap C7 (0.1 μ F “104”) and jumper.

Step 4

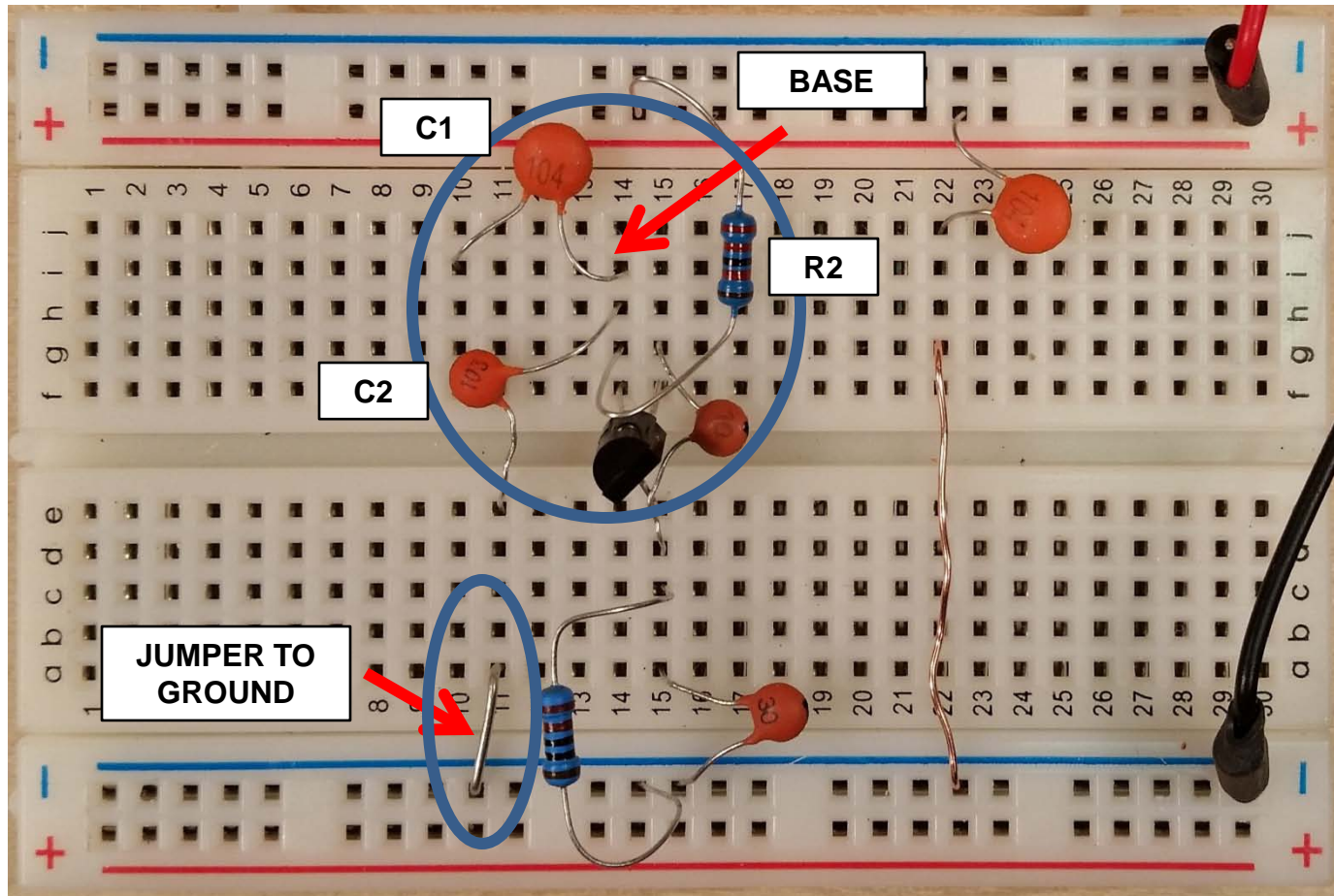

- Install base-circuit components R2 (22 K Ω "RED RED BLK RED BRN"), C1 (0.1 μ F "104"), C2 (0.01 μ F "103"), and jumper.

Step 5

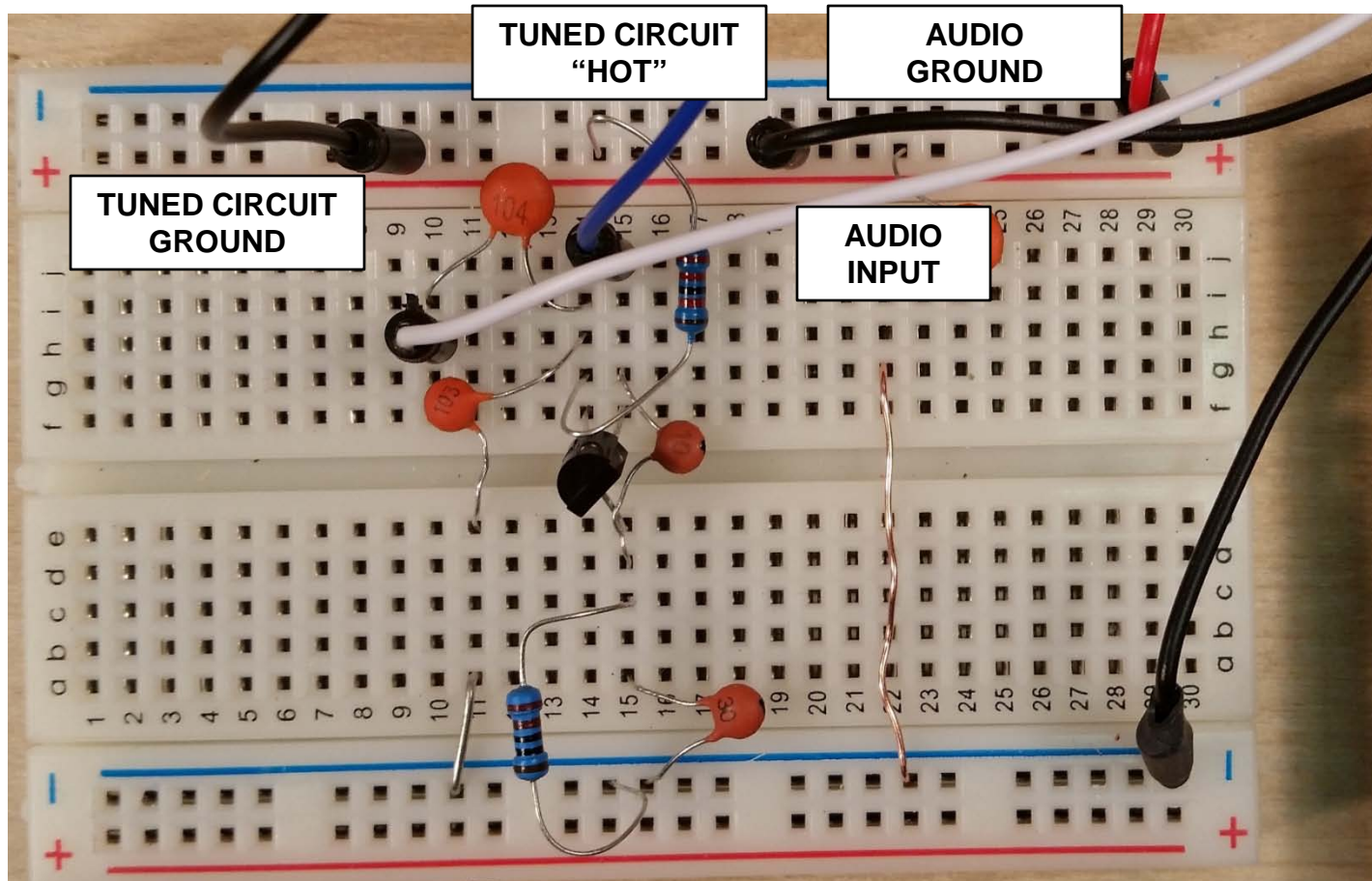

- Connect jumpers from tuned circuit as shown.
- Connect jumpers from the audio jack as shown.

Step 6

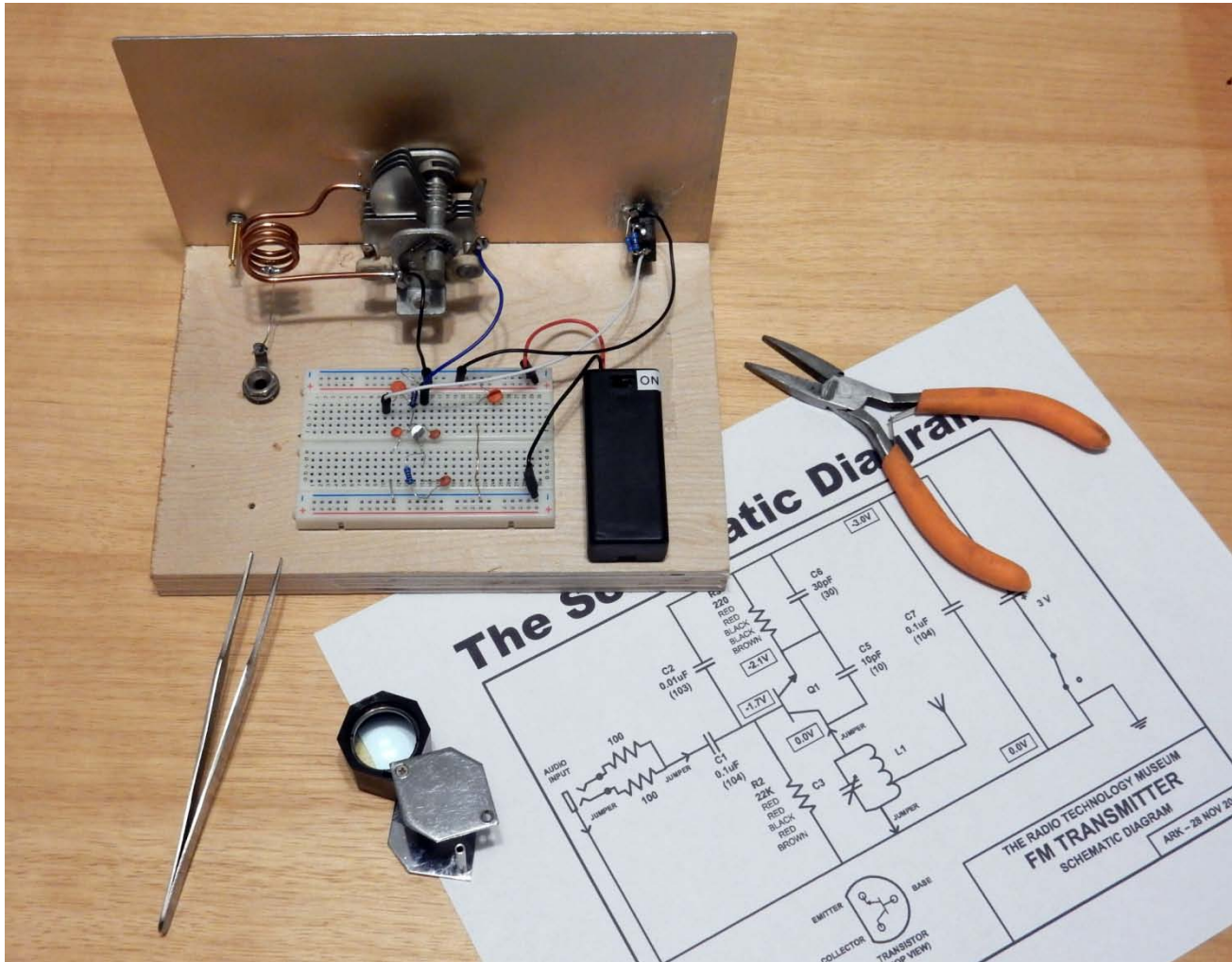

Check connections against the schematic diagram.

Check Out

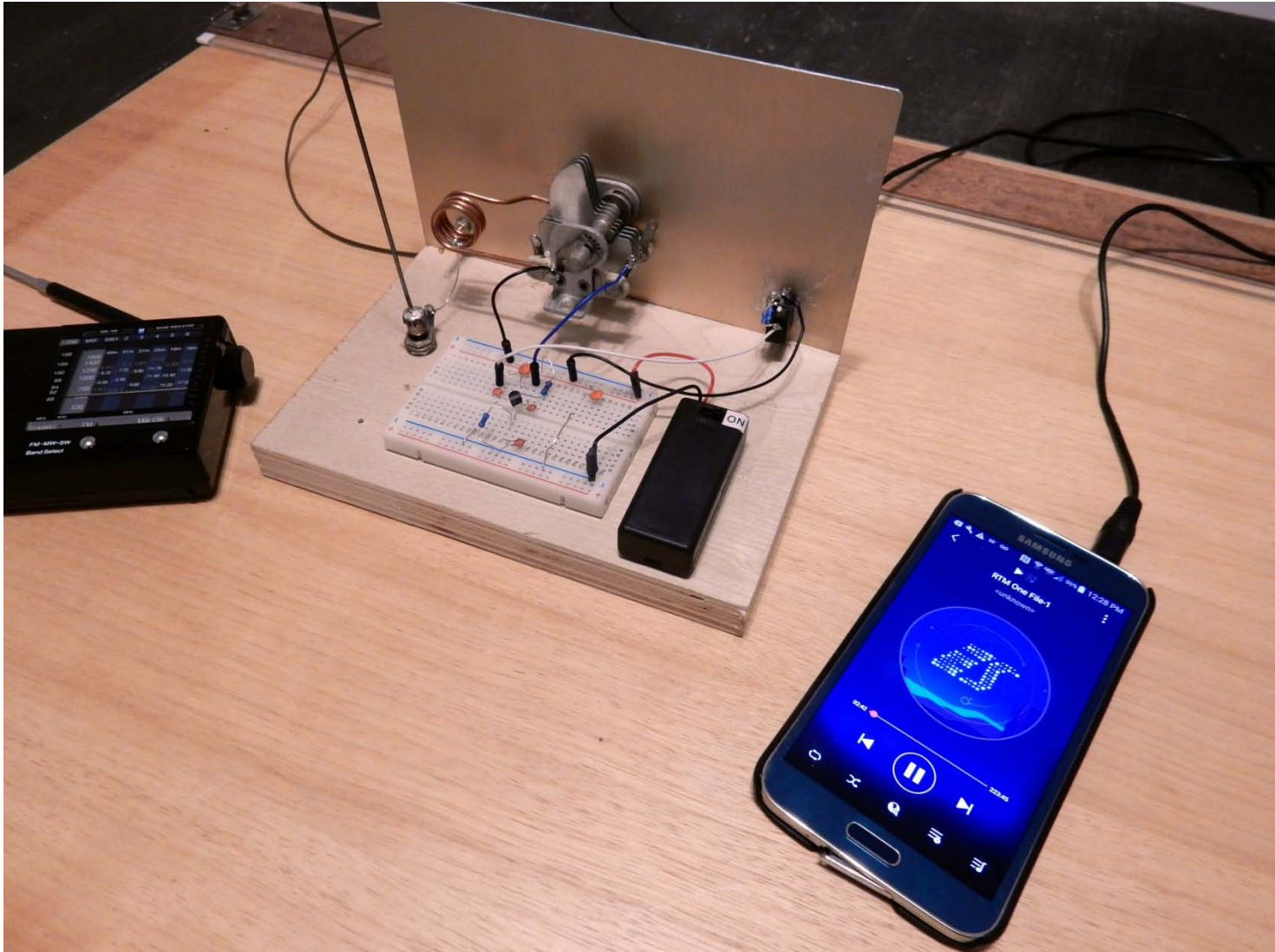

Check Out

- Install antenna rod.
- Connect counterpoise wire to the terminal on the front panel.
- Connect your mobile device to the audio jack. Play some music.
- Turn on the FM receiver.
 - Tune to an unused frequency.
 - Indicated by rushing sound. (White Noise)
 - Place receiver a few feet from the breadboard.
- Turn on the FM transmitter
- Tune the transmitter (knob on panel) to “quiet” the receiver.
- Adjust audio level on the mobile device for minimum distortion.
- You’ll have to readjust the tuning, as bringing you hand near the transmitter changes its frequency.